

1. Assemble the cable chute by joining the acrylic base and sides using chloroform.
2. Assemble the front cable chute support to the end of the chute as shown.
3. Attach the support to the end of the chute as shown. This will be connected to the aluminium extrusions..
4. Linear actuator rail with slide stage/carriage.
5. Bolt a 3D printed adaptor plate to a Torque-free Coaxial Commutator (<https://open-ephys.org/commutators/coaxial-commutator>).
6. Attach the adaptor to the moving stage of the linear actuator rail.
7. Assemble the coupling, attaching the machined motor coupler to the motor shaft and 3D printed motor bracket .
8. Connect the motor onto the linear actuator rail.
9. Bolt a caterpillar track to the 3D printed adaptor plate and attach a 3D printed stopper to it.
10. Bolt 3 aluminium extrusions onto the linear actuator rail. Note: caterpillar stopper and motor bracket are bolted onto the third extrusions.
11. Connect the cable chute to the assembled actuator via the front support by bolting to the extrusion.
12. Attach the chute side support to the chute itself and bolt it to the middle extrusion.

# CABLE CHUTE

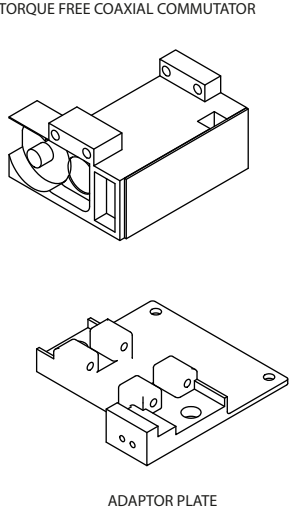

1.

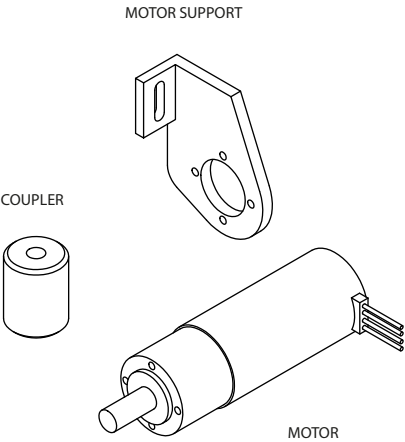
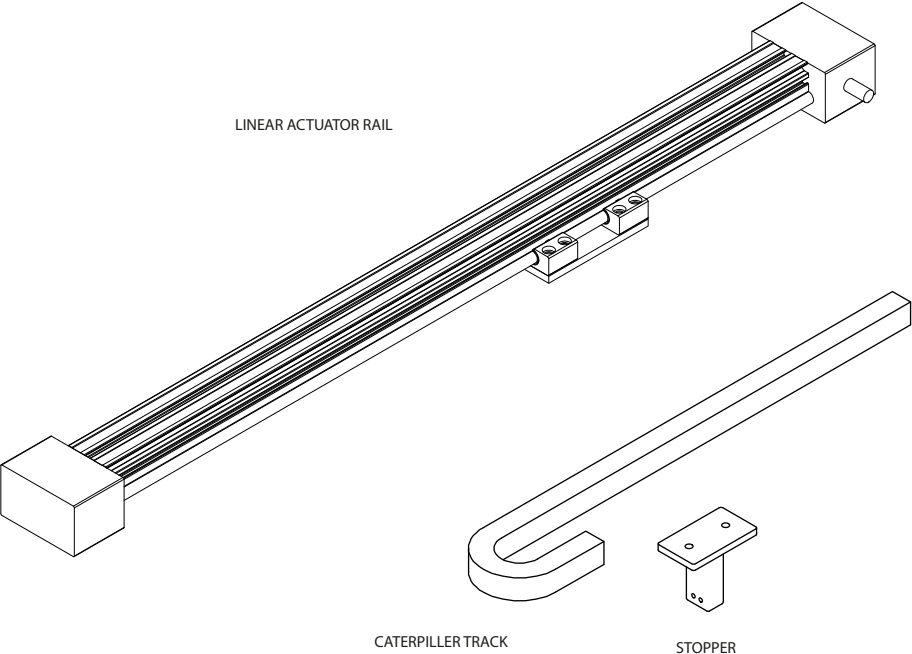
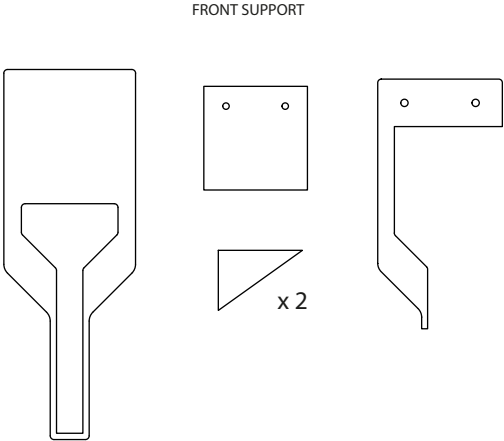
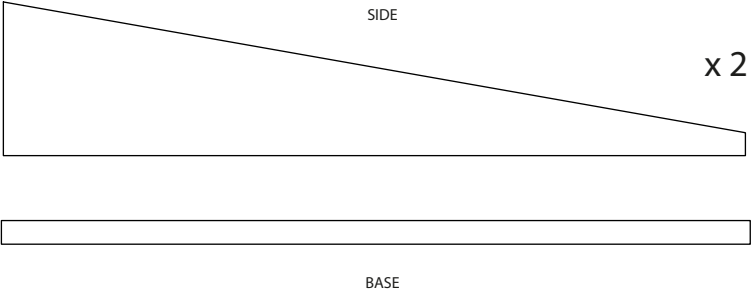
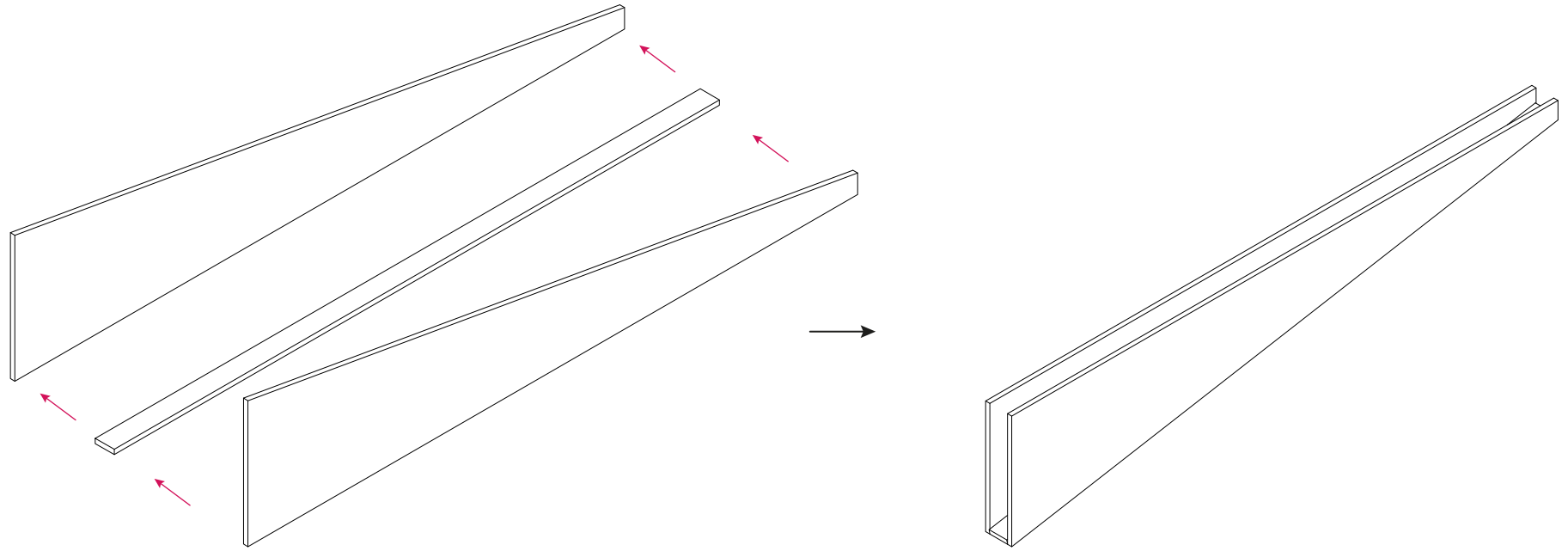

2.



3.

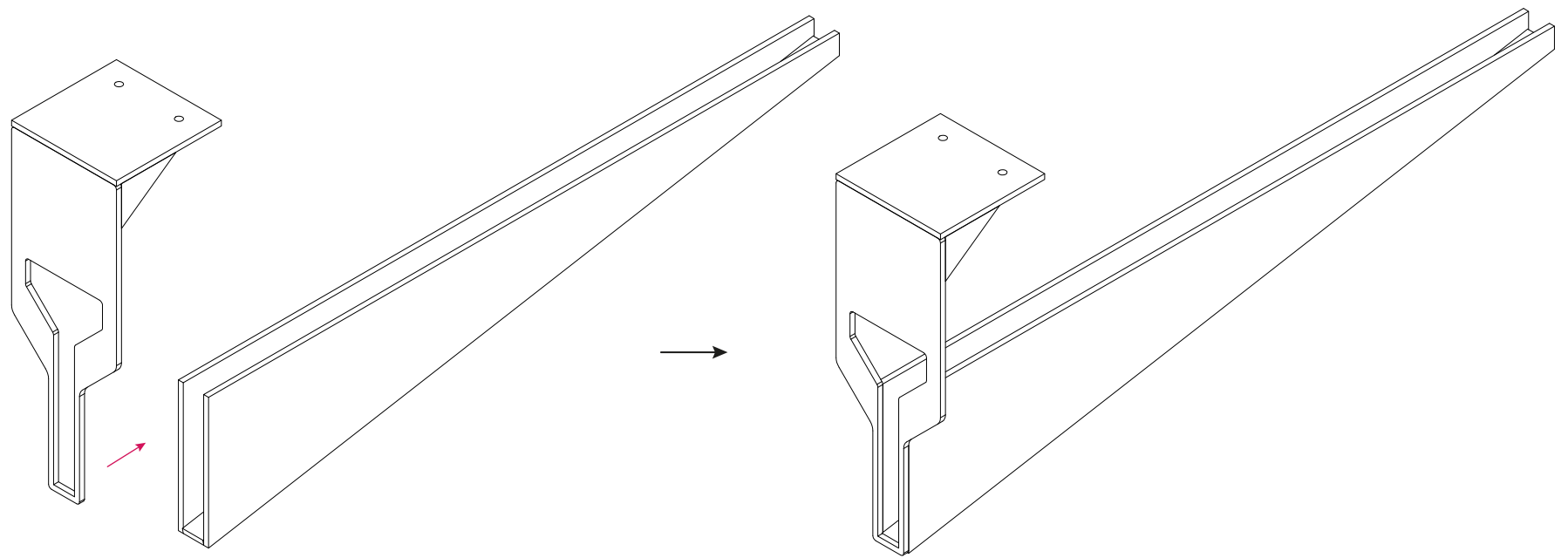

4.

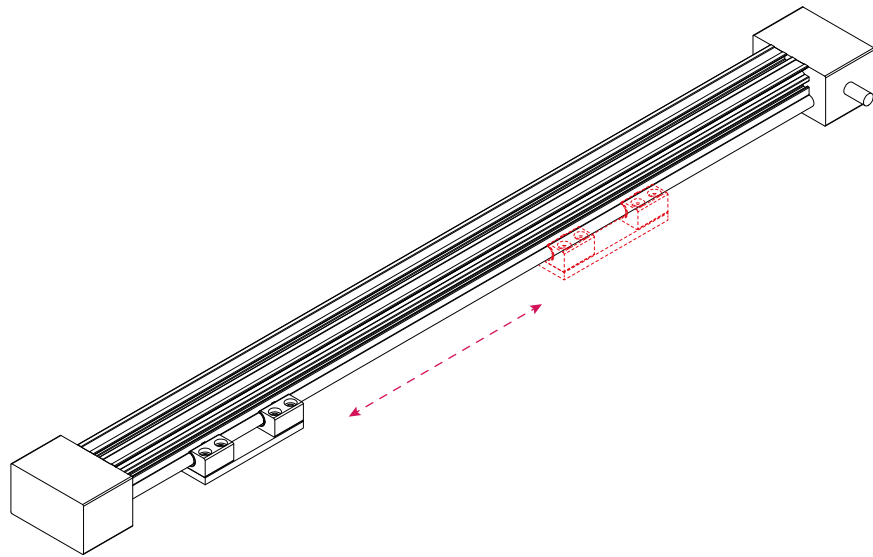

5.

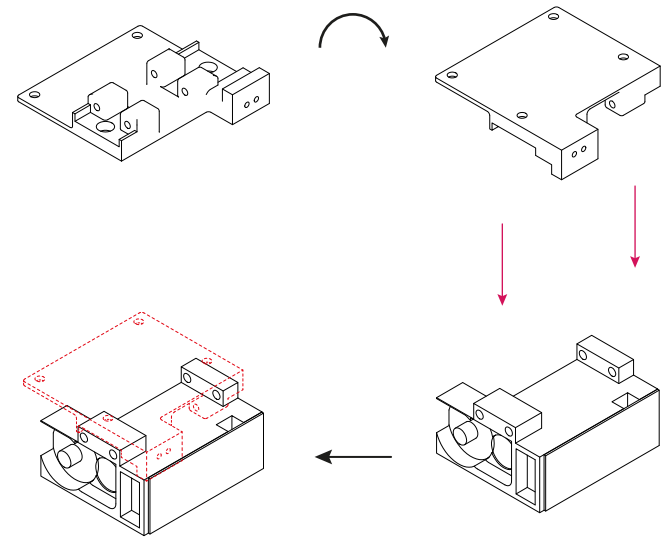

6.

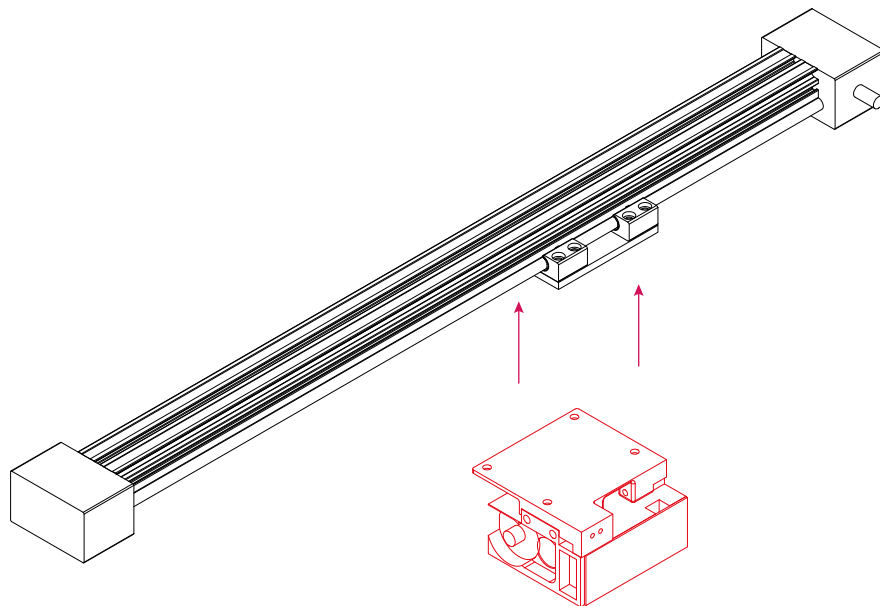

7.

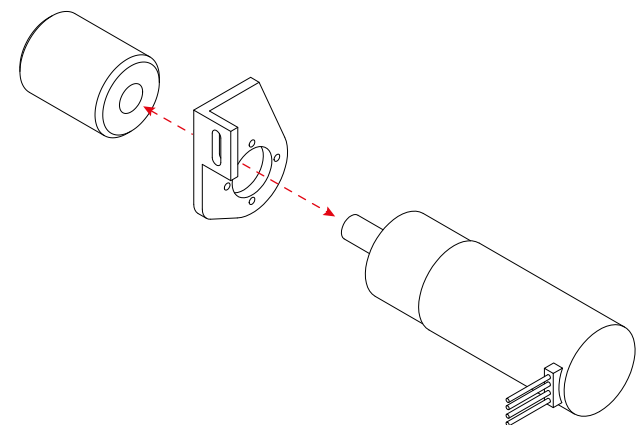

8.

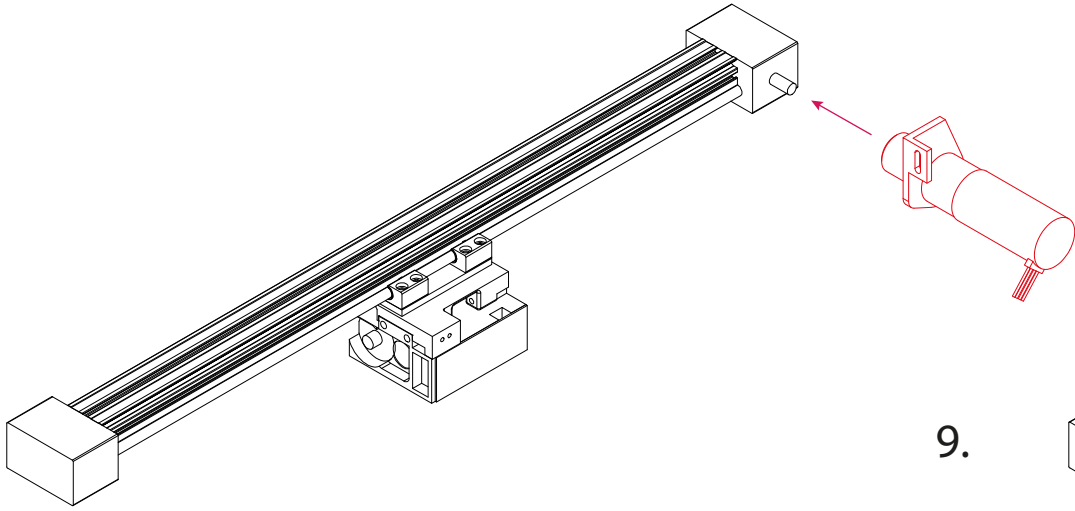

9.

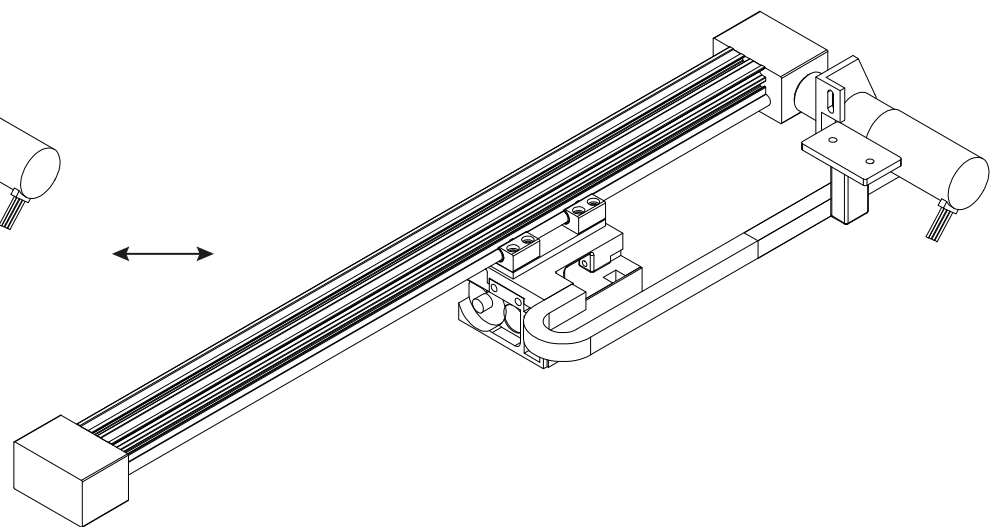
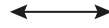
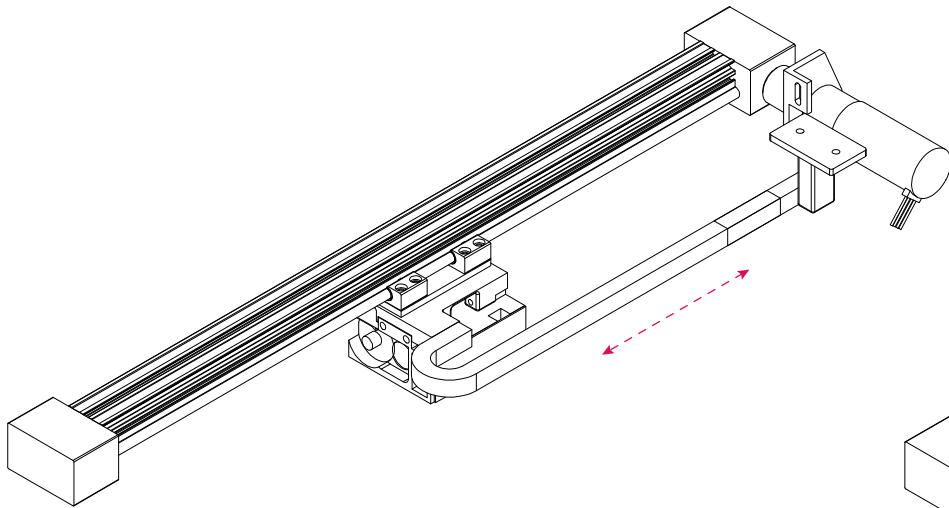
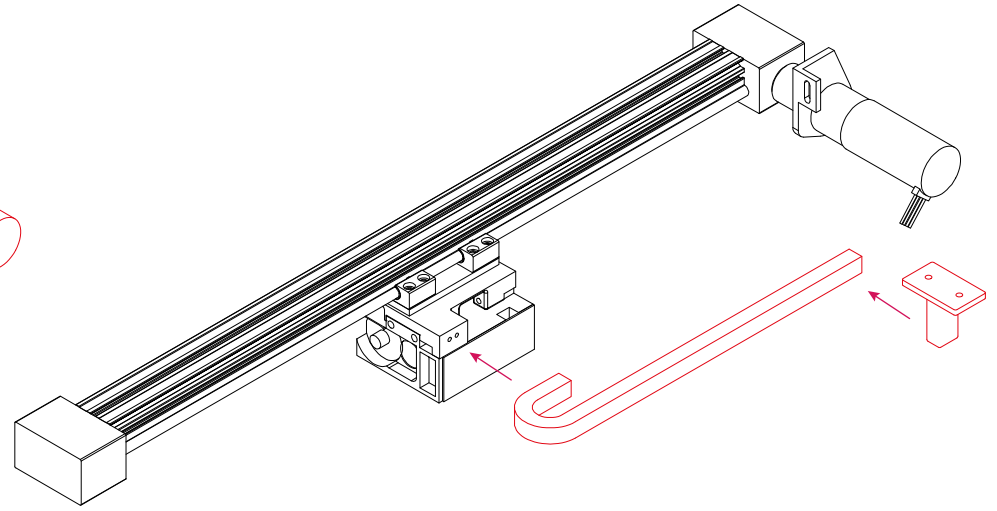

10.

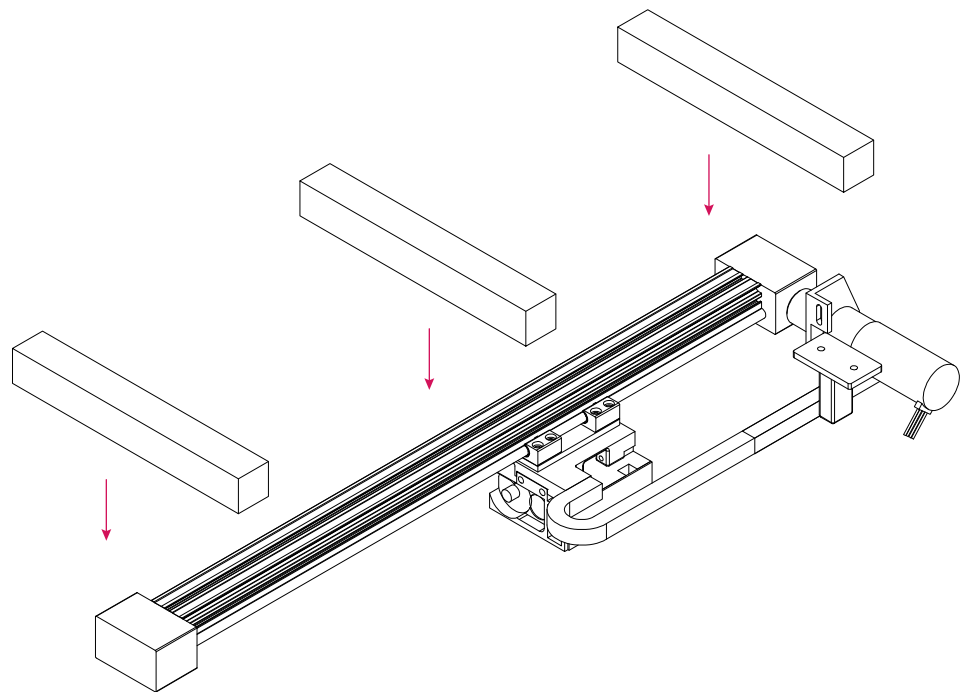

11.

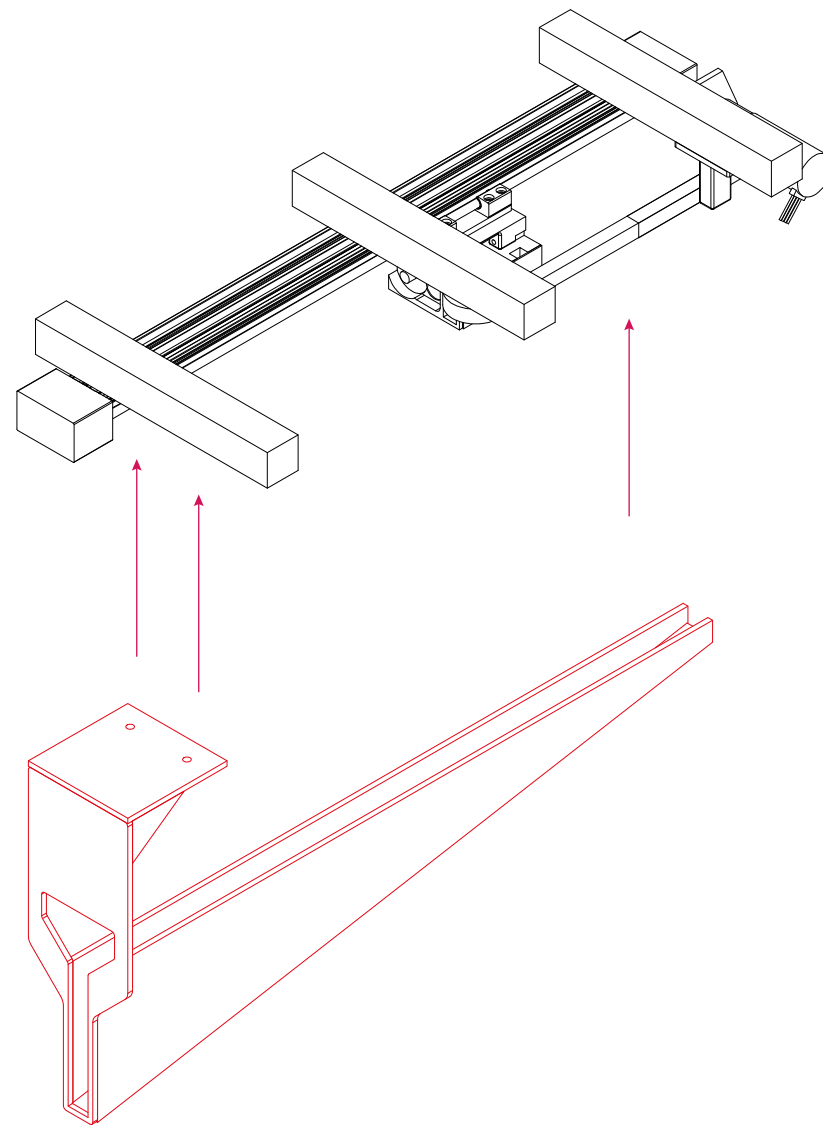

12.

